

## Modular Cooking Range Line EVO700 Electric Tilting Bratt Pan 60lt with Duomat bottom

ITEM # \_\_\_\_\_

MODEL # \_\_\_\_\_

NAME # \_\_\_\_\_

SIS # \_\_\_\_\_

AIA # \_\_\_\_\_



372356 (Z7PPADBAME)

60-lt electric tilting braising  
pan with duomat cooking  
surface, (Watermark) -  
Australia

### Short Form Specification

Item No. \_\_\_\_\_

Infrared heating elements positioned under the cooking surface. Duomat cooking surface for roasting, browning, stewing, preparation of sauces, sautéing, boiling and braising. Can be installed on cantilever systems. Installation on wheels is not available. Mechanism to manually tilt the pan. Double-skinned lid in stainless steel. Cooking temperature can be set through thermostat. Exterior panels in stainless steel with Scotch Brite finish. Height adjustable feet in stainless steel. Right-angled side edges to allow flush-fitting junction between units.

### Main Features

- Infrared heating elements mounted below the cooking surface.
- Actual cooking temperature setting through adjustable thermostat.
- Manual tilting mechanism to facilitate pan emptying.
- Smooth large surfaces, easy access for cleaning.
- Unit to have stainless steel feet with height adjustment up to 50 mm.
- [NOT TRANSLATED]

### Construction

- Cooking surface with **Duomat** bottom: a 10 mm-thick alloy obtained from the combination of 2 different stainless steels for better thermal stability and corrosion resistance.
- Lid in stainless steel to reduce heat dispersion.
- All pan internal surfaces round and polished for better hygiene.
- All exterior panels in Stainless Steel with Scotch Brite finishing.
- One piece pressed 1.5 mm work top in Stainless steel.
- Model has right-angled side edges to allow flush fitting joints between units, eliminating gaps and possible dirt traps.
- Usable capacity of the well 50 liters.
- IPX4 water resistance certification.

### Sustainability

- Heat-insulated: limited heat radiation and low energy consumption.

APPROVAL: \_\_\_\_\_

**Optional Accessories**

- Flanged feet kit PNC 206136
- Frontal kicking strip for concrete installation, 800 mm PNC 206148
- Frontal kicking strip for concrete installation, 1000 mm PNC 206150
- Frontal kicking strip for concrete installation, 1200 mm PNC 206151
- Frontal kicking strip for concrete installation, 1600 mm PNC 206152
- Frontal handrail 800 mm PNC 206167
- Frontal kicking strip, 800 mm PNC 206176
- Frontal kicking strip, 1000 mm PNC 206177
- Frontal kicking strip, 1200 mm PNC 206178
- Frontal kicking strip, 1600 mm PNC 206179
- Frontal handrail 1200 mm PNC 206191
- 4 feet for concrete installation (not for 900 line freestanding grill) PNC 206210
- Right and left side handrails PNC 206240
- Pair of side kicking strips PNC 206249
- Pair of side kicking strips (concrete installation) PNC 206265
- Trolley with lifting and removable tank PNC 922403

**Front**

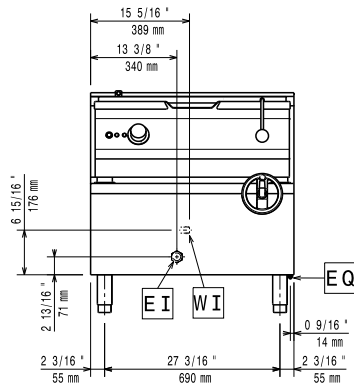

**Side**

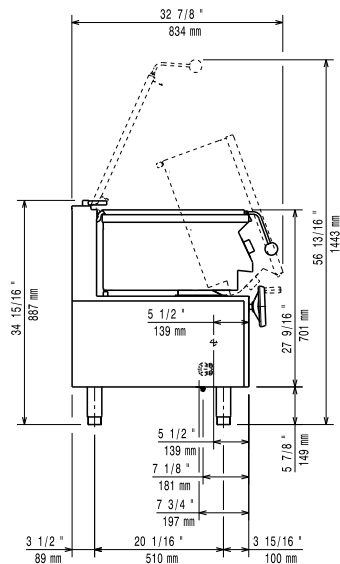

CW11 = Cold Water inlet 1  
EI = Electrical inlet (power)

**Top**

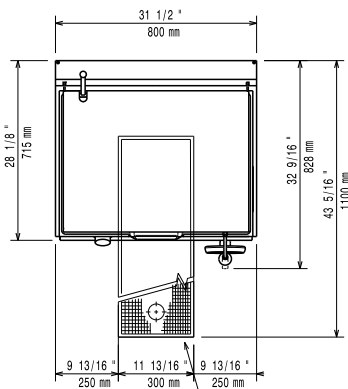

**Electric**

**Supply voltage:**  
372356 (Z7PPADBAME) 380-400 V/3N ph/50/60 Hz

**Total Watts:** 9.5 kW

**Predisposed for:** 380-400V 3N~ 50/60Hz 8.6-9.5kW

**Key Information:**

**Cooking Surface Depth:** 410 mm  
**Cooking Surface Width:** 680 mm  
**Cooking Surface Thickness:** 10 mm  
**Cooking Well Height:** 200 mm  
**Well Capacity, Max:** 60 lt  
**Working Temperature MIN:** 80 °C  
**Working Temperature MAX:** 300 °C  
**Net weight:** 105 kg  
**Shipping weight:** 131 kg  
**Shipping height:** 1080 mm  
**Shipping width:** 820 mm  
**Shipping depth:** 860 mm  
**Shipping volume:** 0.76 m<sup>3</sup>

No clearance needed on rear sides of unit if wall is of non combustible type. If wall is combustible, minimum 50 mm wall clearance should be maintained.